

ACS Annunciators

Honeywell

Overview

EIA-485 specification

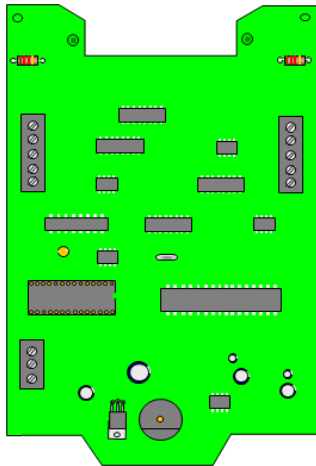
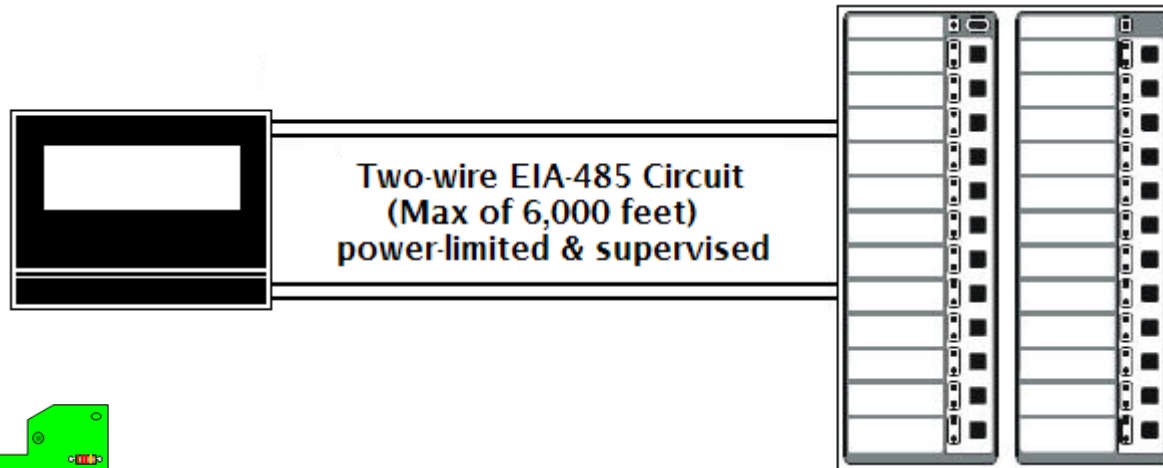

RPT-485

- May extend the length 4,000 feet

ACS Annunciators



LDM-32

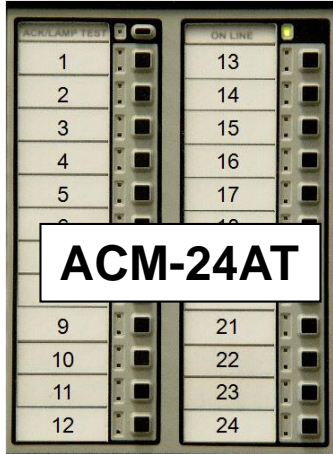

ACM-24AT



ACM-48A



SCS-8

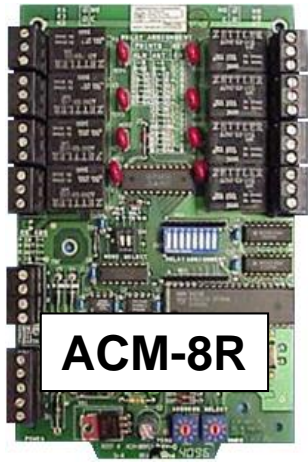

ACM-8R

Overview



LDM-32

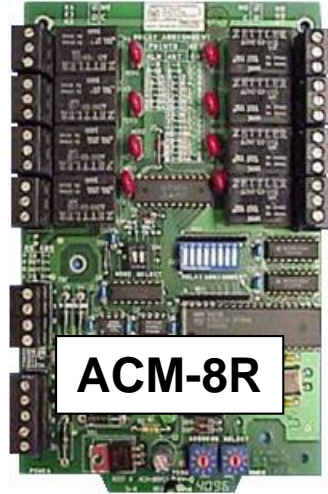

ACM-8R

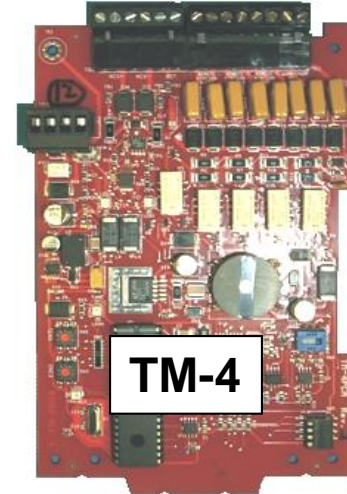

TM-4

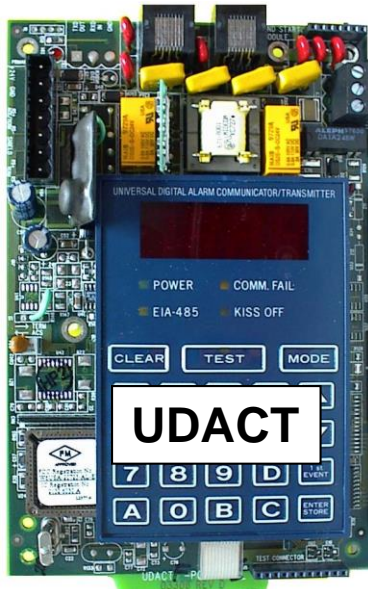

UDACT



SCS-8

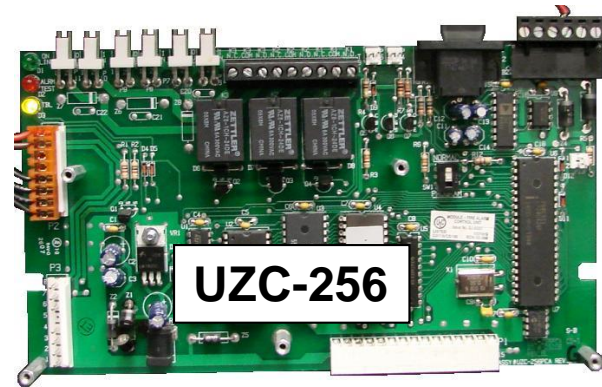

UZC-256

ACM-24AT and ACM-48A

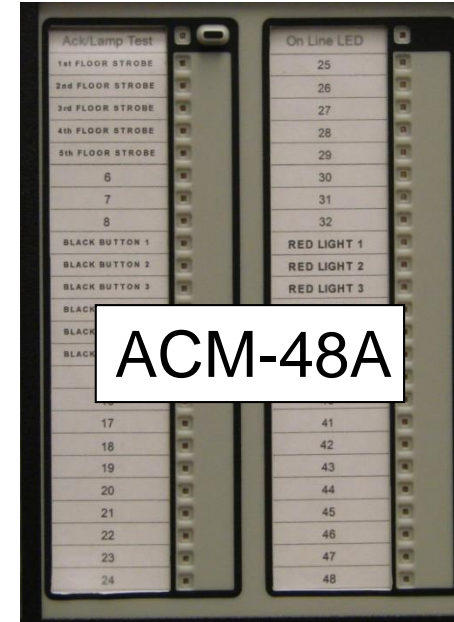
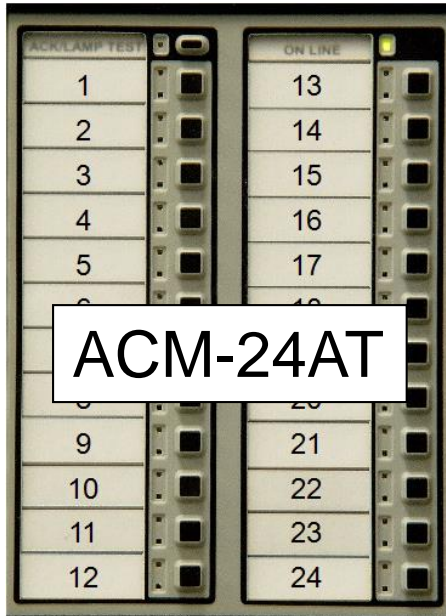

CONTROL for:

- SLC Relay
- NAC Control Modules
- Speaker Circuits
- Software Zones

- **Visual** Indication ONLY

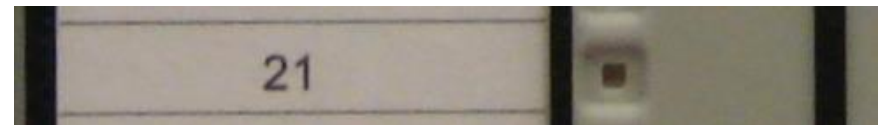

Address Wheels

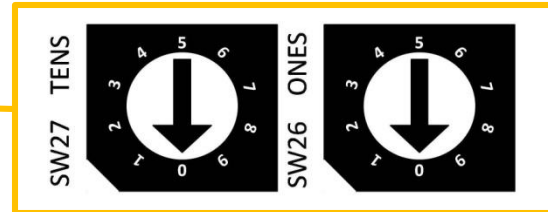

ACS 1	*	ACS 9	*	ACS 17	*	ACS 25	*	<input type="checkbox"/> Terminal <input type="checkbox"/> ACS
ACS 2	*	ACS 10	*	ACS 18	*	ACS 26	*	
ACS 3	*	ACS 11	*	ACS 19	*	ACS 27	*	
ACS 4	*	ACS 12	*	ACS 20	*	ACS 28	*	
ACS 5	*	ACS 13	*	ACS 21	*	ACS 29	*	
ACS 6	*	ACS		NFS-320 / NFS2-640 MAP		*	*	
ACS 7	*	ACS				*	*	
ACS 8	*	ACS				*	*	

A1	None	A12	None	A23	None
A2	None	A13	None	A24	None
A3	None	A14	None	A25	None
A4	None	A15	None	A26	None
A5	None	A16	None	A27	None
A6	None	A17	None	A28	None
A7	None	A18	None	A29	None
A8	None	NFS2-3030 / NCA-2 MAP		None	None
A9	None			None	None
A10	None			None	None
A11	None	A22	None	Clear All Maps	

End of Line Resistor

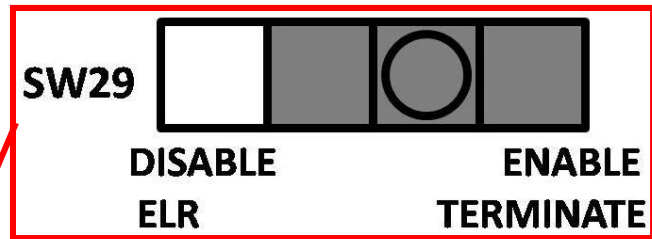

Power Connection

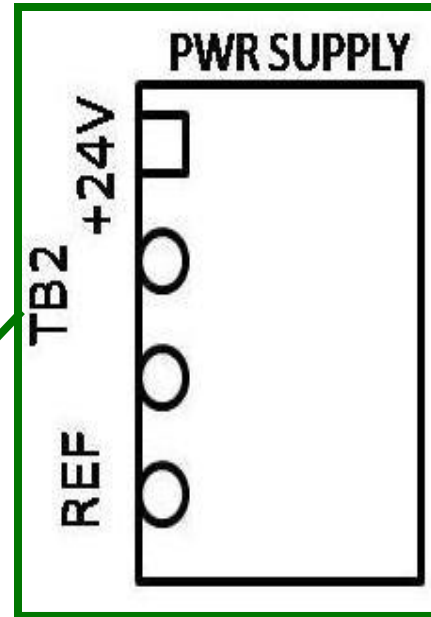

24V

ACS Connection

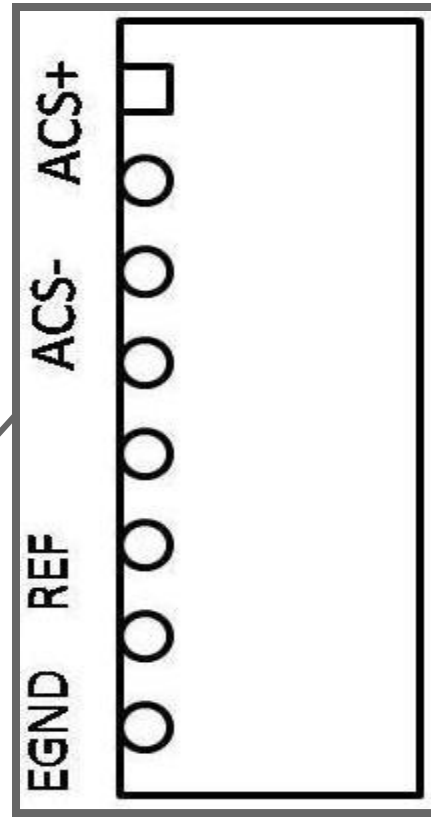

RETROFIT CONSIDERATIONS

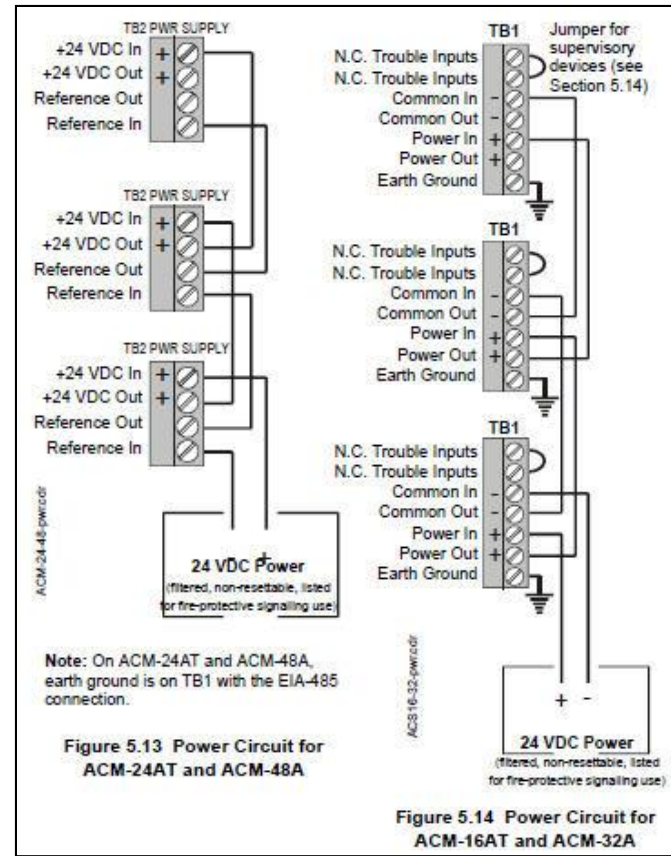
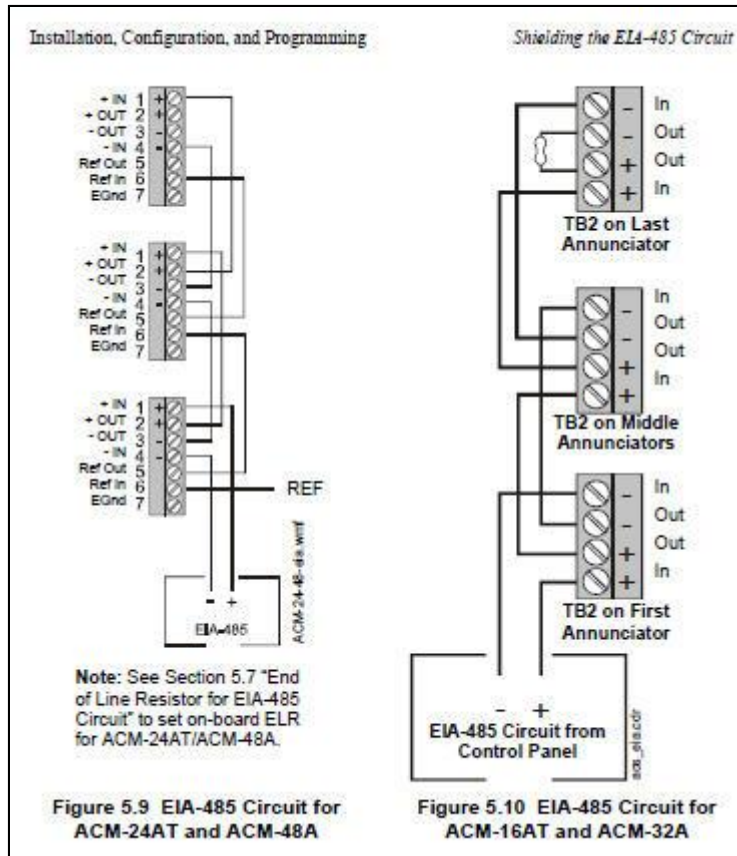

EIA-485 Circuits

Power Circuits

Address Expansion

- A 64 point map exceeds physical points on an annunciator
- So we add an expander

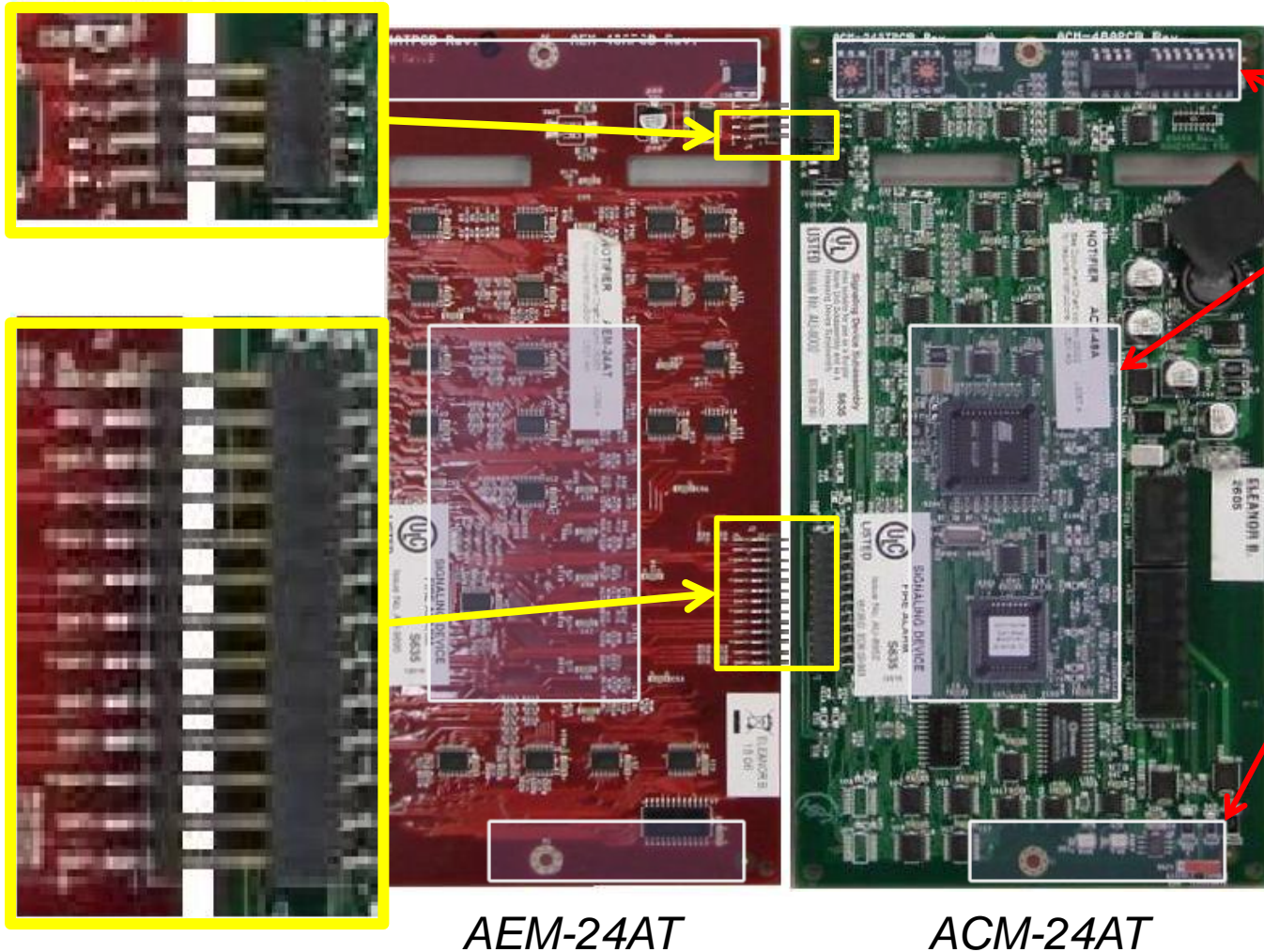

AEM-24AT

ACM-24AT

ACM-24AT with 64-Point Limit

Honeywell

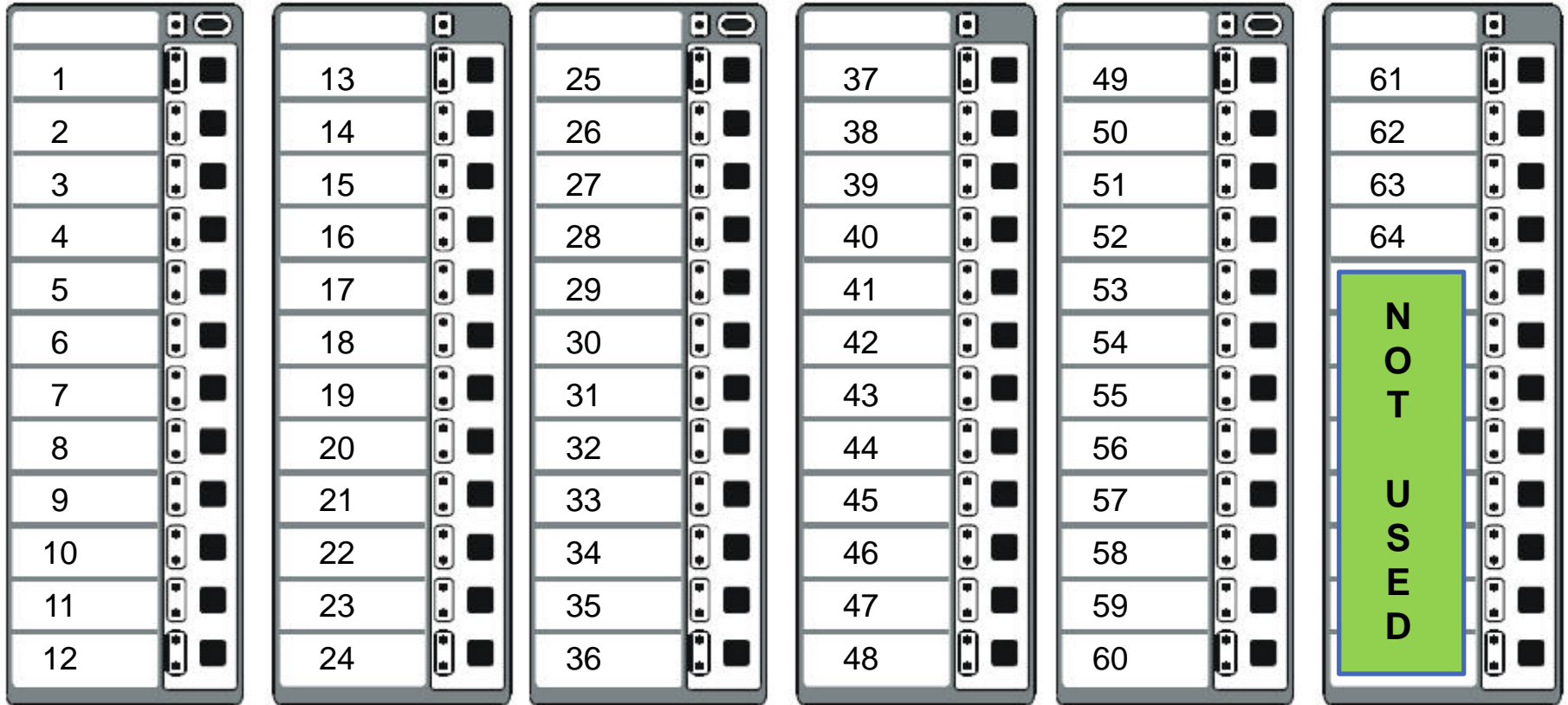

ACM-24AT

Set Address Intelligence resides on board

AEM-24AT

Expansion annunciators connect to communication bus and receive information through host ACM

AEM-24AT

ACM-48A with 64-Point Limit

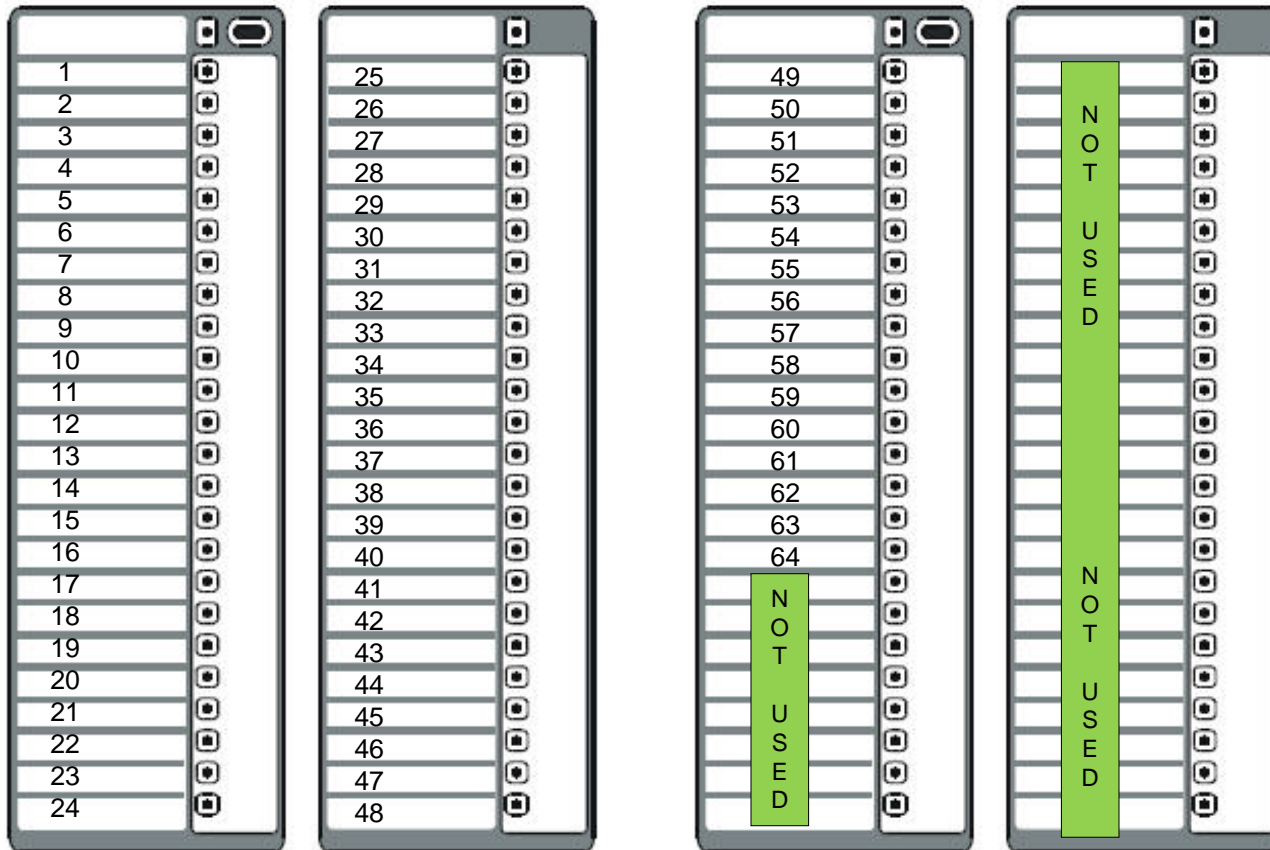

ACM-48A

Set Address
Intelligence
resides on board

AEM-48A

Expansion annunciators connect to
communication bus and receive
information through host ACM

ACM-24AT with 96-Point Limit

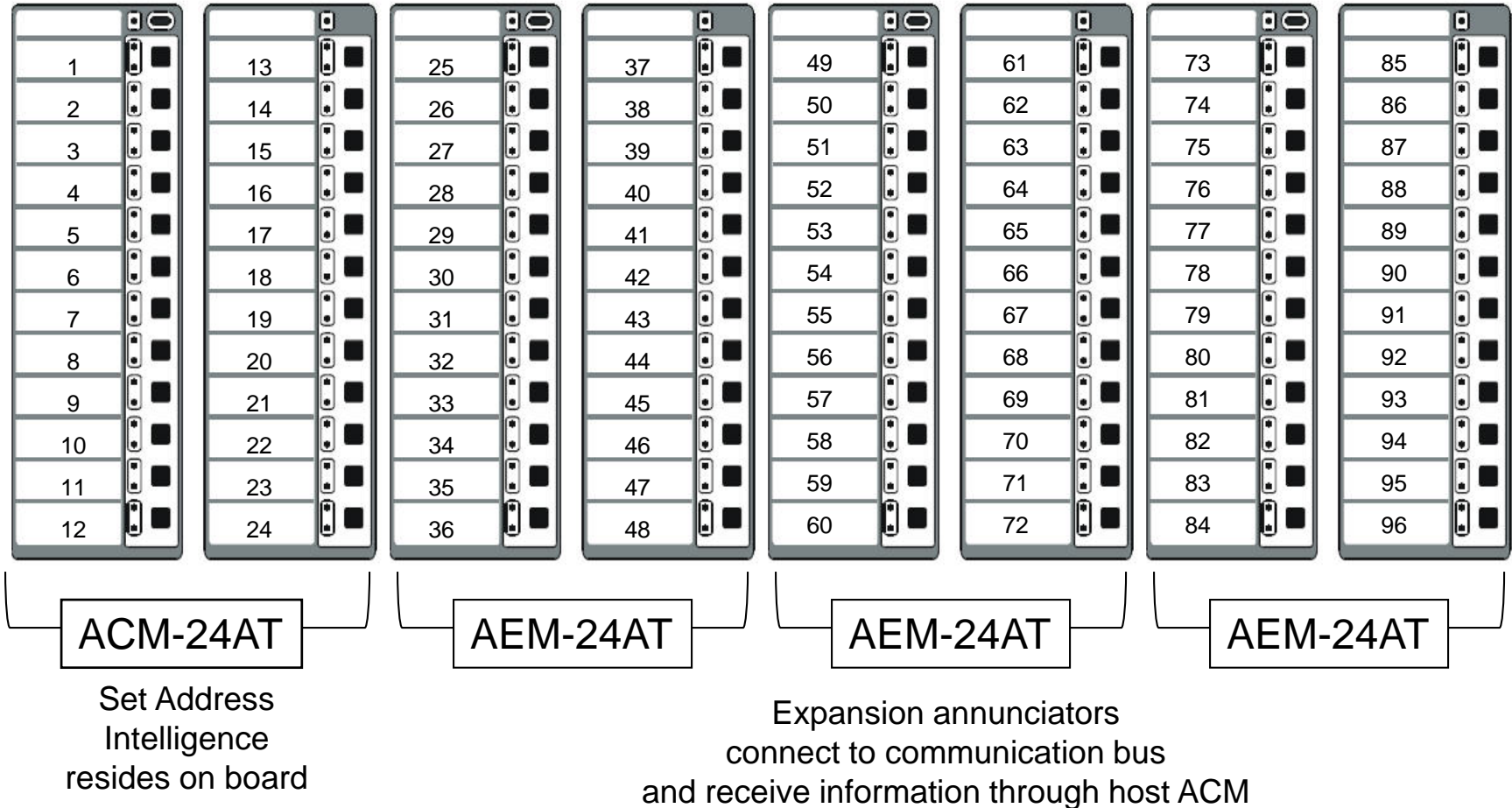

ACM-48A with 96-Point Limit

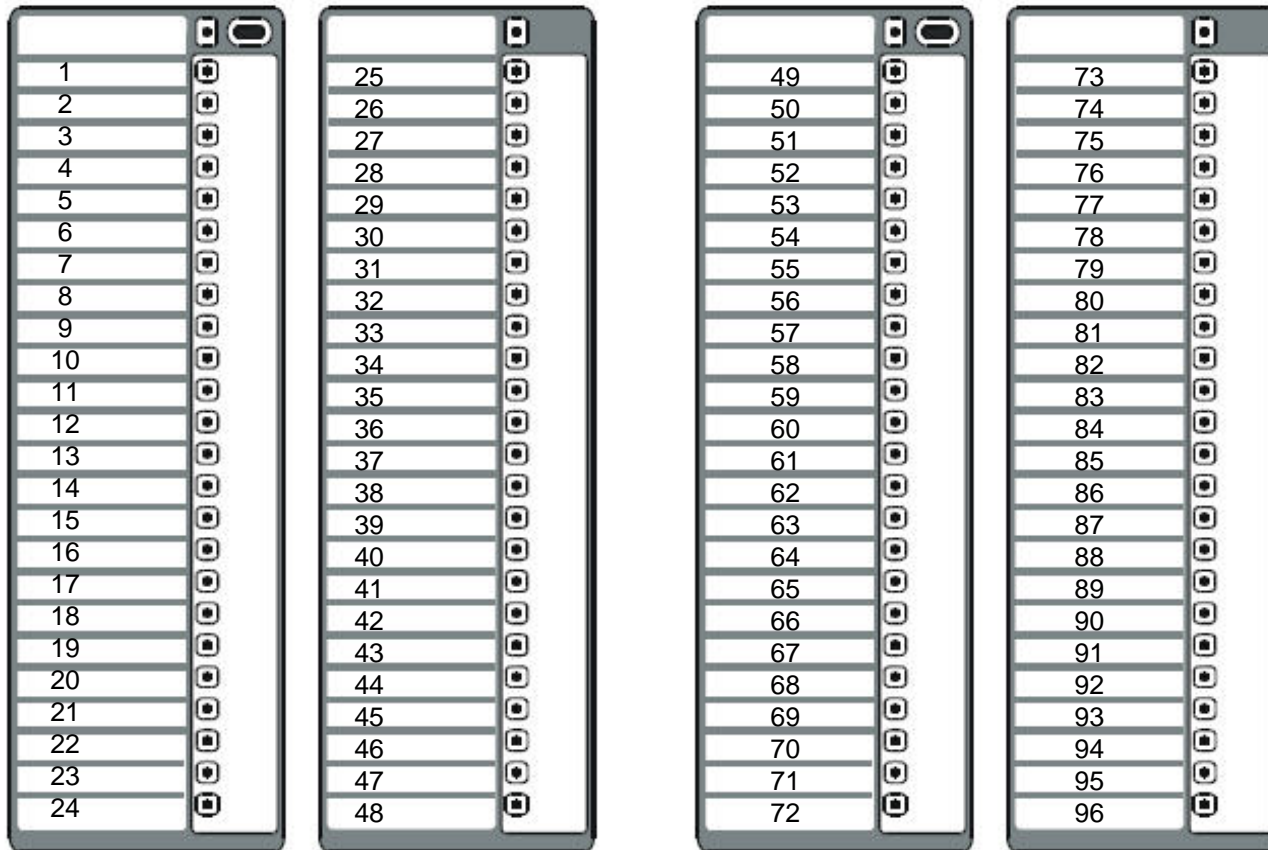

ACM-48A

Set Address
Intelligence
resides on board

AEM-48A

Expansion annunciators connect to
communication bus and receive
information through host ACM

DOORS

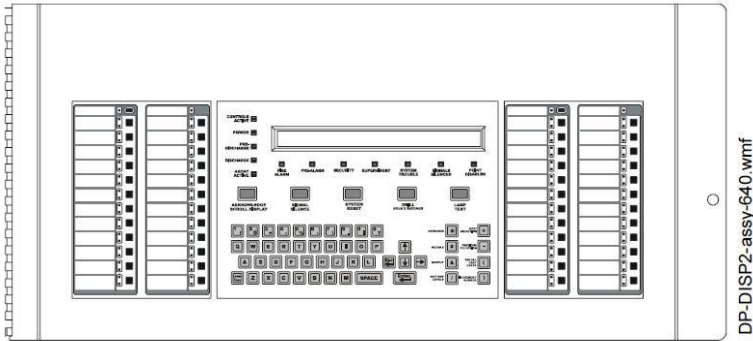

DP-DISP2 (Shown with NFS2-640 and one ACM-24AT)

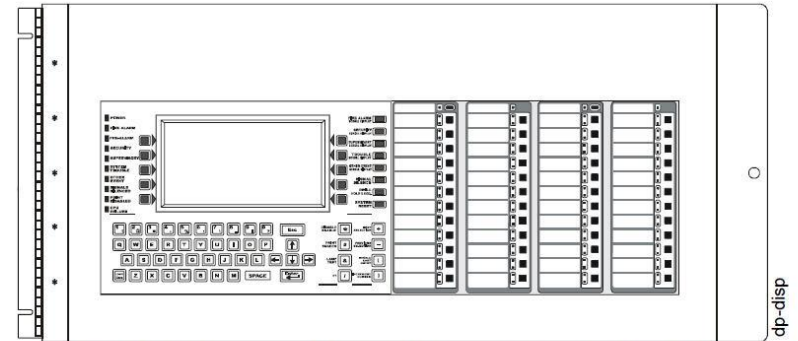

DP-DISP (Shown with the NCA and Two ACM-24AT Modules)

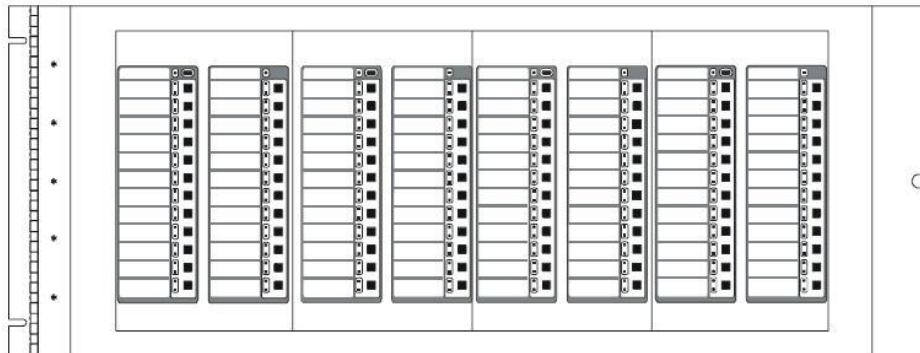

ADP-4B (Shown with ACM-24AT Modules)

Address Wheel Relationship

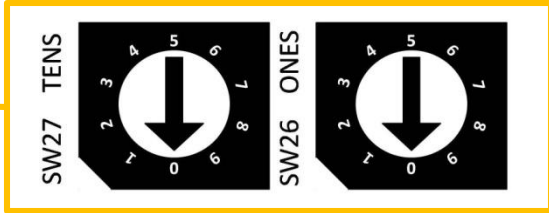

ACS 1	*	ACS 9	*	ACS 17	*	ACS 25	*	<input type="checkbox"/> Terminal <input type="checkbox"/> ACS
ACS 2	*	ACS 10	*	ACS 18	*	ACS 26	*	
ACS 3	*	ACS 11	*	ACS 19	*	ACS 27	*	
ACS 4	*	ACS 12	*	ACS 20	*	ACS 28	*	
ACS 5	*	ACS 13	*	ACS 21	*	ACS 29	*	
ACS 6	*	ACS 14	*	ACS 22	*	ACS 30	*	
ACS 7	*	ACS 15	*	ACS 23	*	ACS 31	*	
ACS 8	*	ACS 16	*	ACS 24	*	ACS 32	*	

1

6

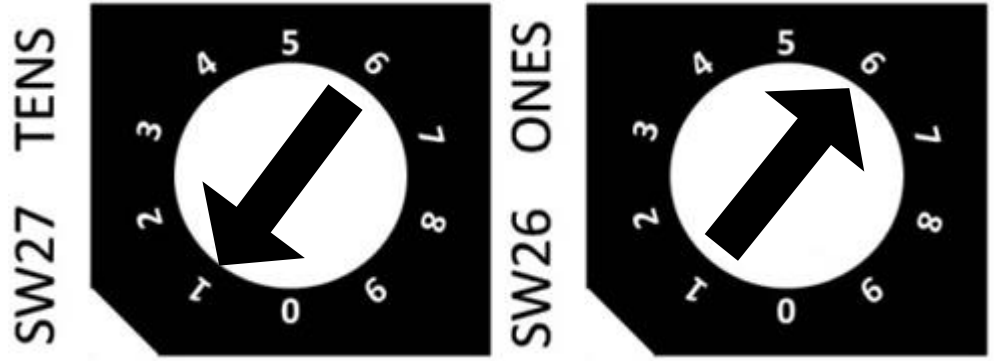

Questions

Honeywell